

PMX 98 MIXER

551.083

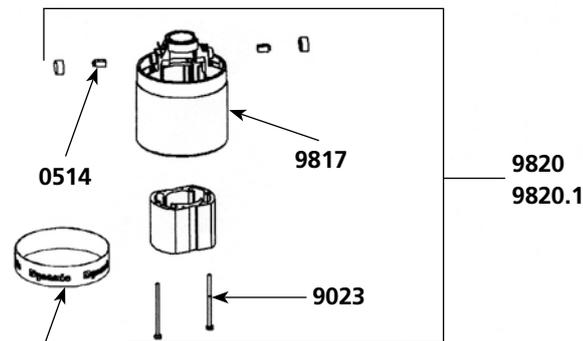

9810
9810.1

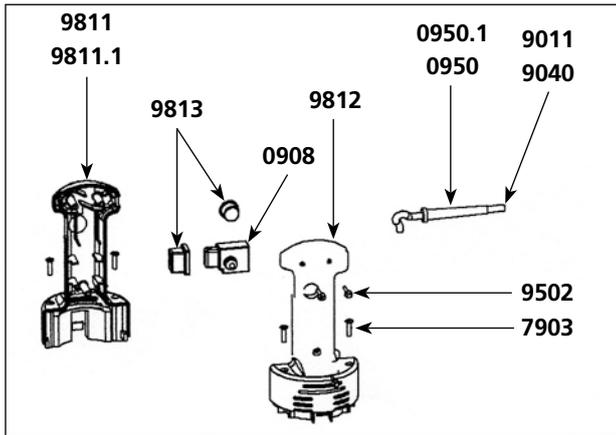

0726

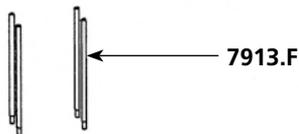
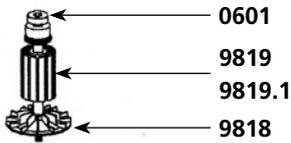

9025

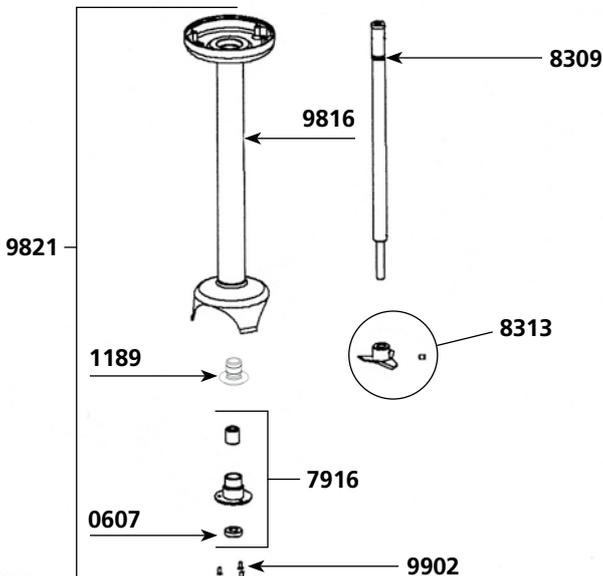

Parts list

Code

Carbon brushes (2)	0514
Ball bearing	0601
Waterproof seal	0607
Squeezing washer	0726
Wall bracket	089959
Non-locking switch	0908
Strain relief 230 V	0950
Strain relief 115V	0950.1
Capacitor	0972.1
Warning label	1017
Dynamic label	1027
Label w/ serial number 230 V	1063
Label w/ serial number 115 V	1064
Bearing holder + seal	1189
Speed variator (option) (230V)	1213
Speed variator (option) (115V)	1214
Brace screws (4)	7903
Braces (4)	7913.F
Lower ball bearing assembly	7916
Shaft	8309
Cutter blade w/ screw	8313
Power cord 230 V	9011
Stator screws (2)	9023
Ball bearing ring	9025
Power cord 115 V	9040
Power cord (Australian)	9066
Power cord (Australian)	9067
Handle screws (3)	9502
Complete handle 230 V	9810
Complete handle 115 V	9810.1
Lower half handle w/ label 230 V	9811
Lower half handle w/ label 115 V	9811.1
Upper half handle	9812
Switch protector (2)	9813
Motor & shaft housing + bearing	9816
Upper motor casing (w/ carbon brushes holders)	9817
Fan	9818
Rotor 230 V	9819
Rotor 115 V	9819.1
Stator 230 V (w/ carter, carbon brushes holders)	9820
Stator 115 V (w/ carter, carbon brushes holders)	9820.1
Complete foot assembly	9821
Shaft, lower ball bearing & cutter assembly	9836
Lower bearing screws (3)	9902

