

MOULIN N°5

INSTRUCTIONS

ASSEMBLY

1. Set the hopper on the brim of a pan: the support bears two side hooks provided for this purpose.
 2. Place the sieve with the 3 slots facing the 3 studs, than rotate it slightly, without blocking it.
 3. The shaft-handle and cross-piece assembly are then centred on the sieve spindle and blocked as the right place with the two holding springs placed on each side of the hopper.
- The two clips of the cross-piece are used to hold the two springs.

The triturator is ready for use.

DISMANTLING

1. Press on the two holding springs, in order to have the clips of the cross-piece drop down by themselves. Pull out the shaft by rotating it clockwise, so as to keep clear of the stopping blade.
2. Seize the sieve in both hands, by the outer side, and unfasten with a dead blow anti-clockwise.

NOTE

When the machine is new, the inside of the sieve is rough, in order to make the L.T. TRITURATOR effective. On the contrary, when the inside of the sieve is becoming smooth, it must be replaced.

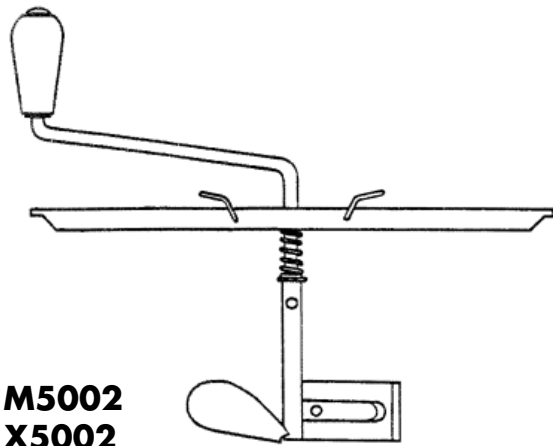

**M5002
X5002**
shaft, handle and cross-piece assembly



**M5003
X5003**
holding spring

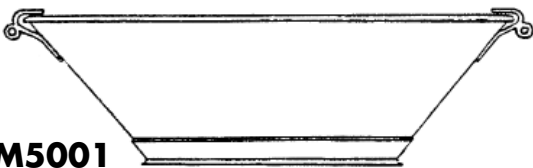

**M5001
X5001**
hopper with holding springs

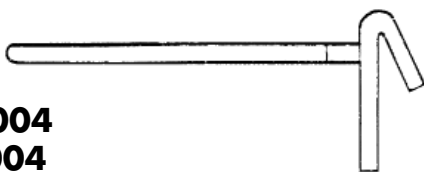

**M5004
X5004**
hopper support

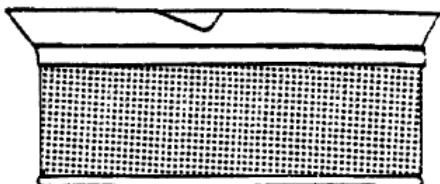

**M5010-15-20-30-40
X5010-15-20-30-40**
sieve

full-sized sieve perforations

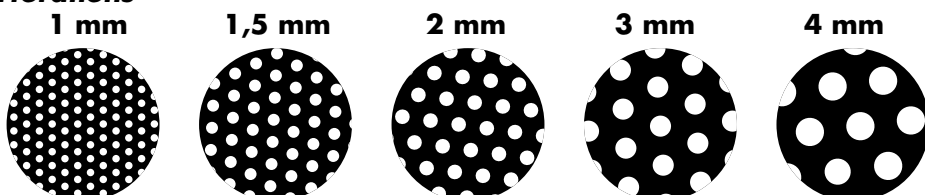

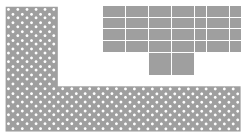

*208.030 **MOULIN** - MANUAL

MOULIN N°5

INSTRUCTIONS

MONTAGE

1. Disposer le cône sur le bord d'une marmite: les deux crochets latéraux du support sont prévus à cet effet.
2. Placer la grille, les 3 encoches face aux 3 tétons, et la tourner légèrement sans qu'il soit utile de le serrer.
3. L'ensemble arbre - manivelle - traverse se centre alors sur le pivot de la grille et sa bloque à l'emplacement prévu à l'aide des deux ressorts de fixation disposés de chaque côté du cône.

Les 2 étriers de la traverse maintiennent les 2 ressorts.

Le Moulin est prêt à servir

DÉMONTAGE

1. Appuyer sur les deux ressorts de fixation, les étriers de la traverse tombent d'eux-mêmes. Sortir l'Arbre en le tournant dans le sens de rotation afin d'éviter la palette d'arrêt.
2. Prendre la grille deux mains, par l'extérieur et desserrer «d'un coup sec» dans le sens contraire au mouvement.

REMARQUE

Lorsque l'appareil est neuf, l'intérieur de la grille est très rugueux, ce qui est un facteur d'efficacité du MOULIN.L.T. Aussi, il est bien évident que lorsque l'intérieur de la grille devient lisse, il est alors nécessaire de la remplacer.

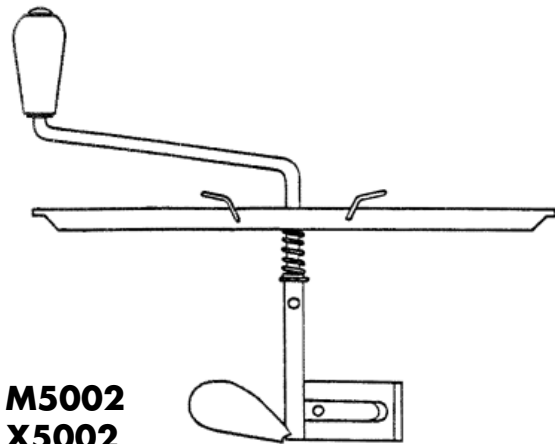

M5002
X5002

ensemble arbre-manivelle-traverse



M5003
X5003

ressort d'accrochage

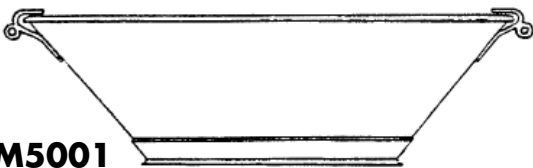

M5001
X5001

cone-support avec ressorts d'accrochage

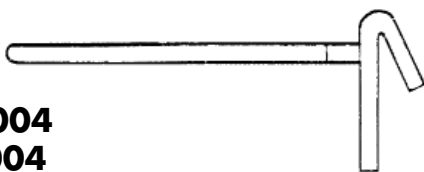

M5004
X5004

cercie-support

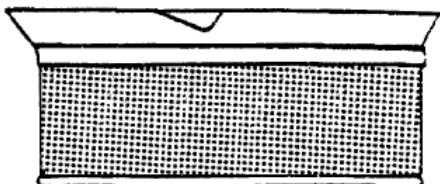

M5010-15-20-30-40
X5010-15-20-30-40

grille

perforations, grandeur nature, de grilles

1 mm

1,5 mm

2 mm

3 mm

4 mm

