

DISPOSITION DES COMMANDES
CONTROL PANEL
ANORDNUNG DER SCHALTRE

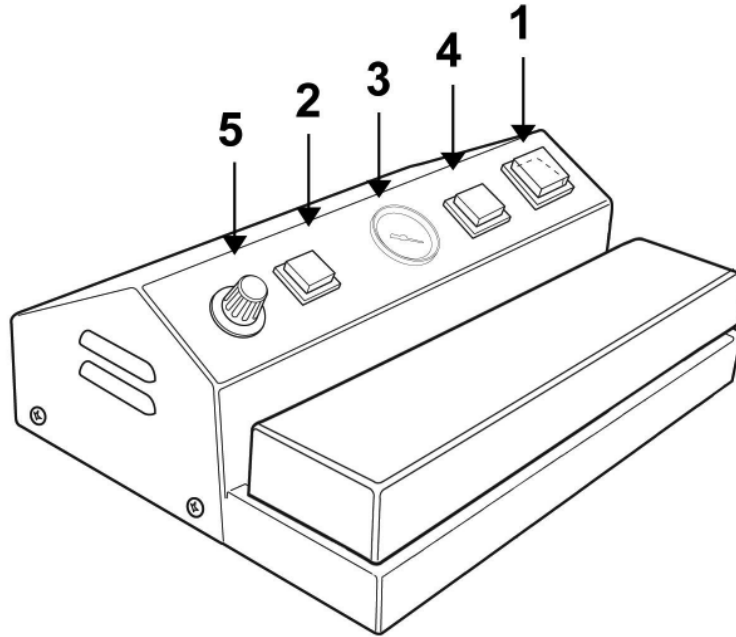

- 1 - Interrupteur général
- 2 - Poissoir de pompe
- 3 - Videmetre
- 4 - Poissoir de soudage
- 5 - Temps de soudage

- 1 - General cut-out switch
- 2 - Pump push button
- 3 - Vacuum gauge
- 4 - Welding push button
- 5 - Welding timer

- 1 - Hauptshalter
- 2 - Pumpentaste
- 3 - Vakuummeter
- 4 - Schweistaste
- 5 - Schweistimer

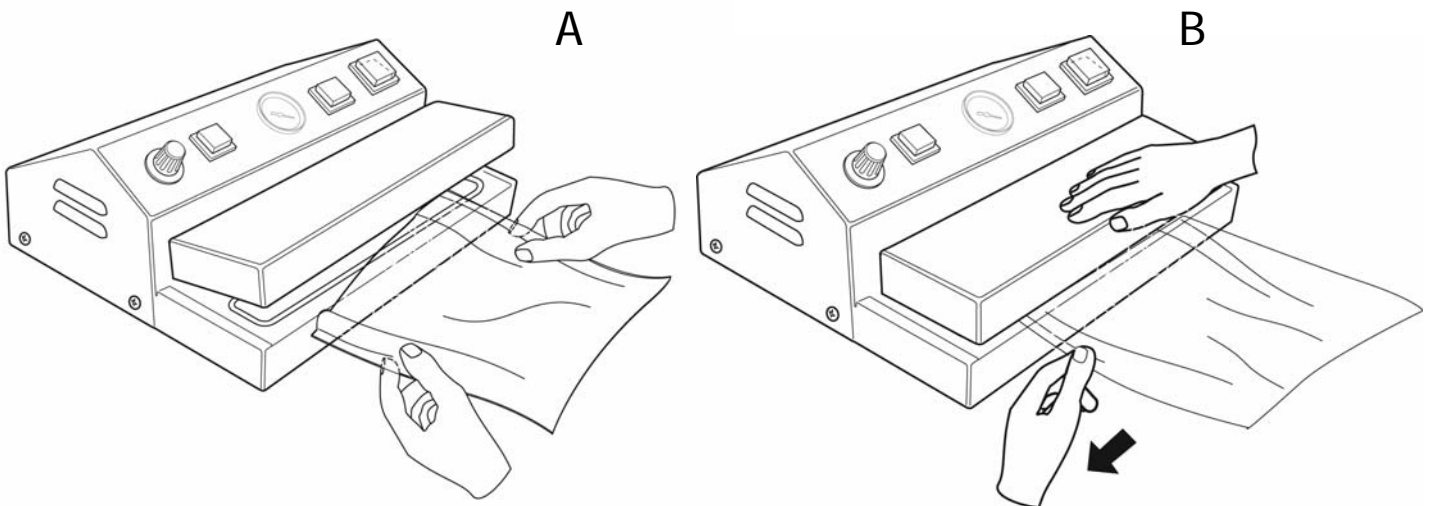

*516.020 **VACUUMMACHINE** - MANUAL

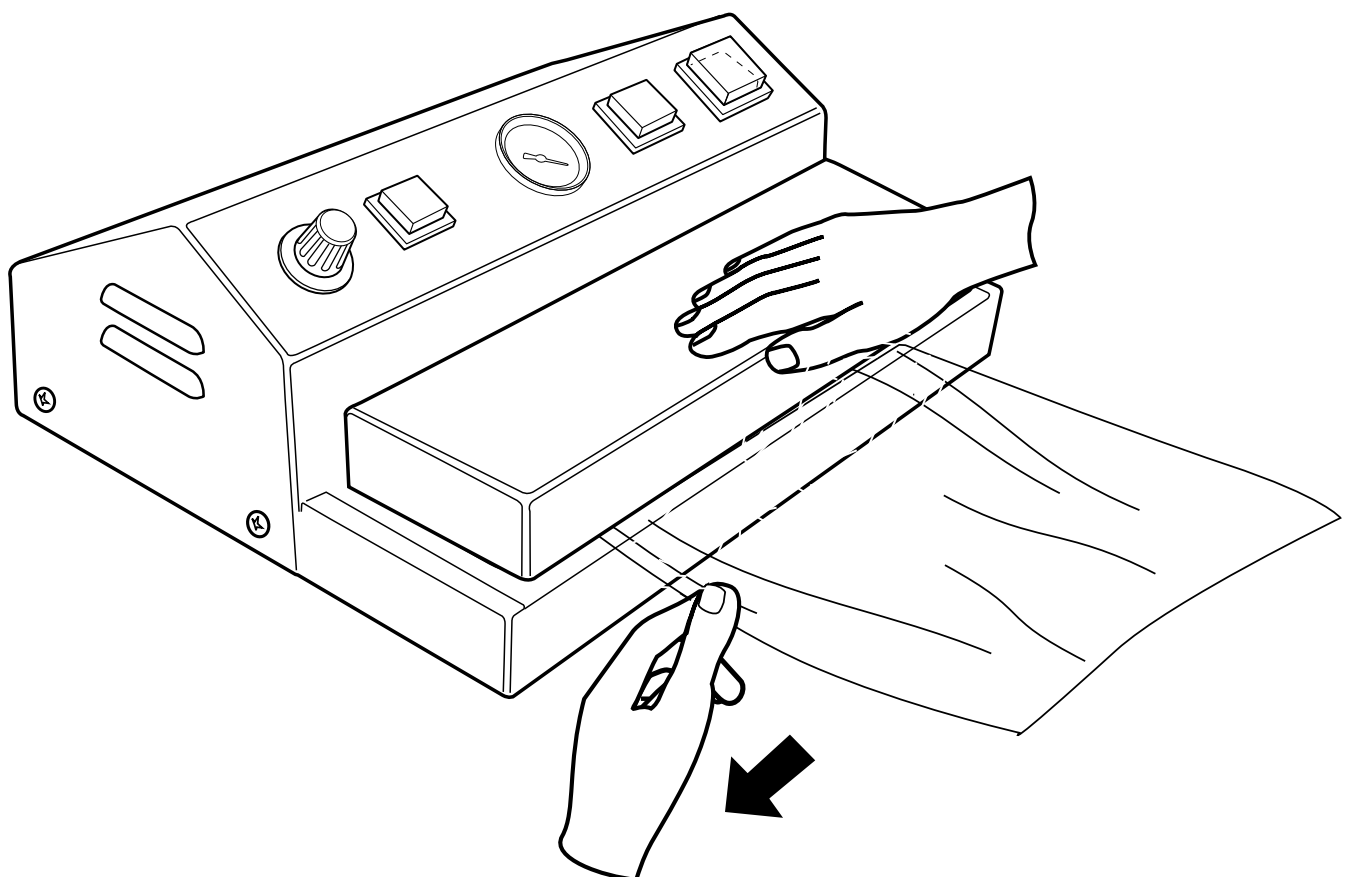
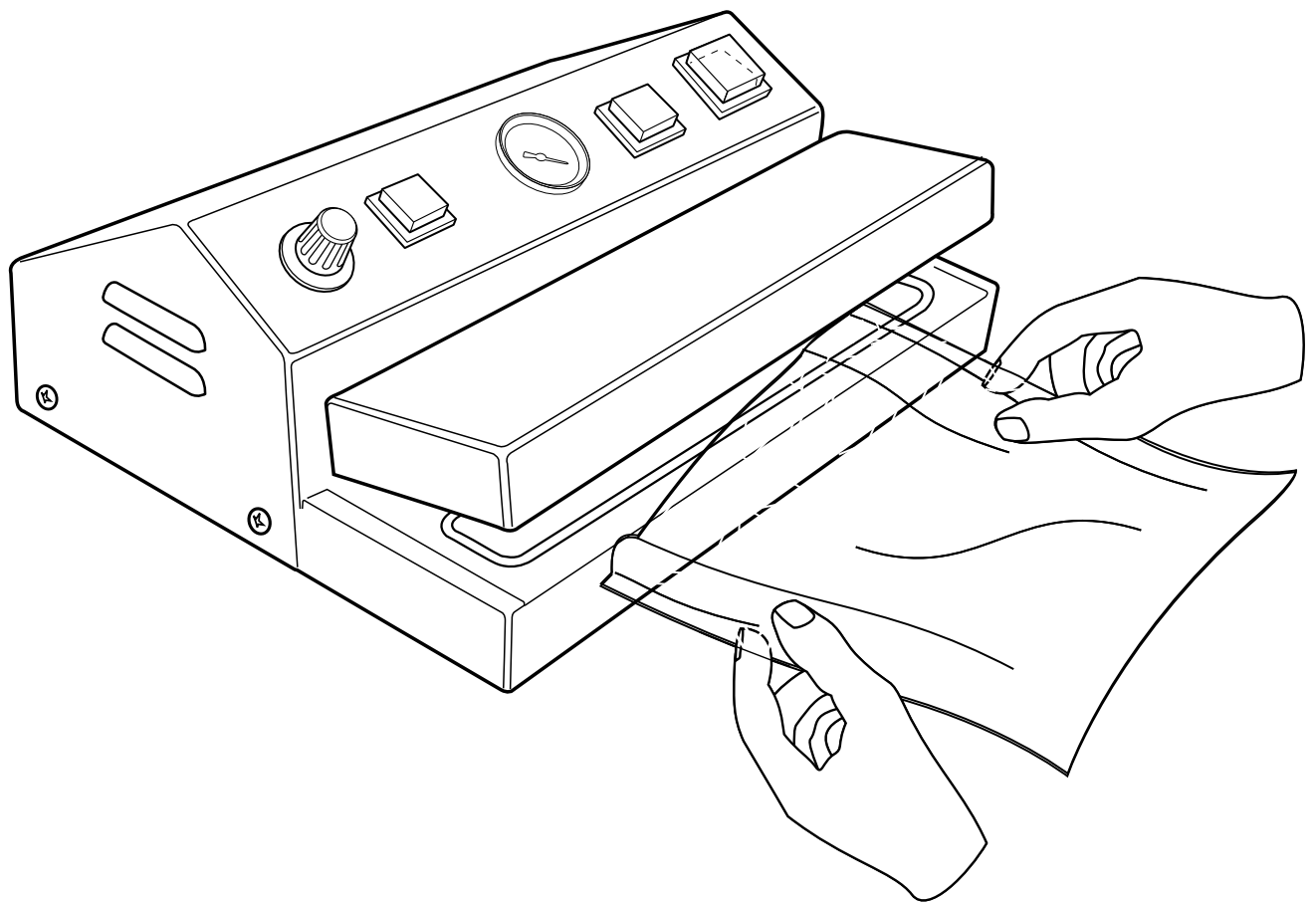

*516.020 **VACUUMMACHINE** - MANUAL

Jolly steel

Operating Instructions

Set seal timer (5) on No. 4. Insert the product inside the bag and then hold it about 4 centimeters from the mouth, positioning it above and about one centimeter overlapping the black seal. Stop when your fingers touch the edge of the machine. Then proceed to seal, holding the bag with one hand and lowering the cover with the other. Press down until the vacuum gauge pointer goes beyond No. 02. When there is sufficient vacuum press the seal push-button (4) and then wait until the vacuum pump automatically turns off.

Suggestion

The bag must be the right size for the product. Welding timer (5) must be adjusted according to the thickness of the bag. A thicker bag requires a longer welding time and vice-versa. Aspiration can be fast or slow depending on the ratios: product/bag/bag thickness. With certain types of meat the machine may aspirate blood. This will not enter the pump but stops inside the seal, which must be cleaned. If liquid has been aspirated make another weld right after the first weld. If wrinkles are formed along the weld repeat the weld procedure. Before welding the bag spread it out with your hands to eliminate any air bubbles. Be careful when packaging meat with bones since bones could puncture the bag.

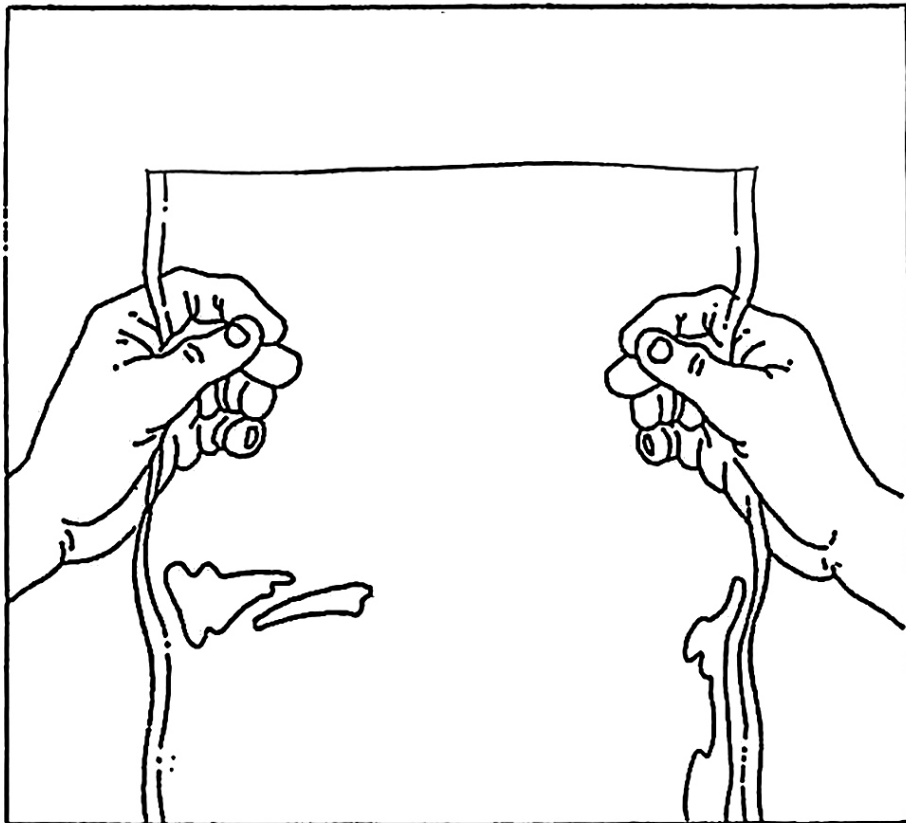

(H)

Move from left to right to create some wrinkles

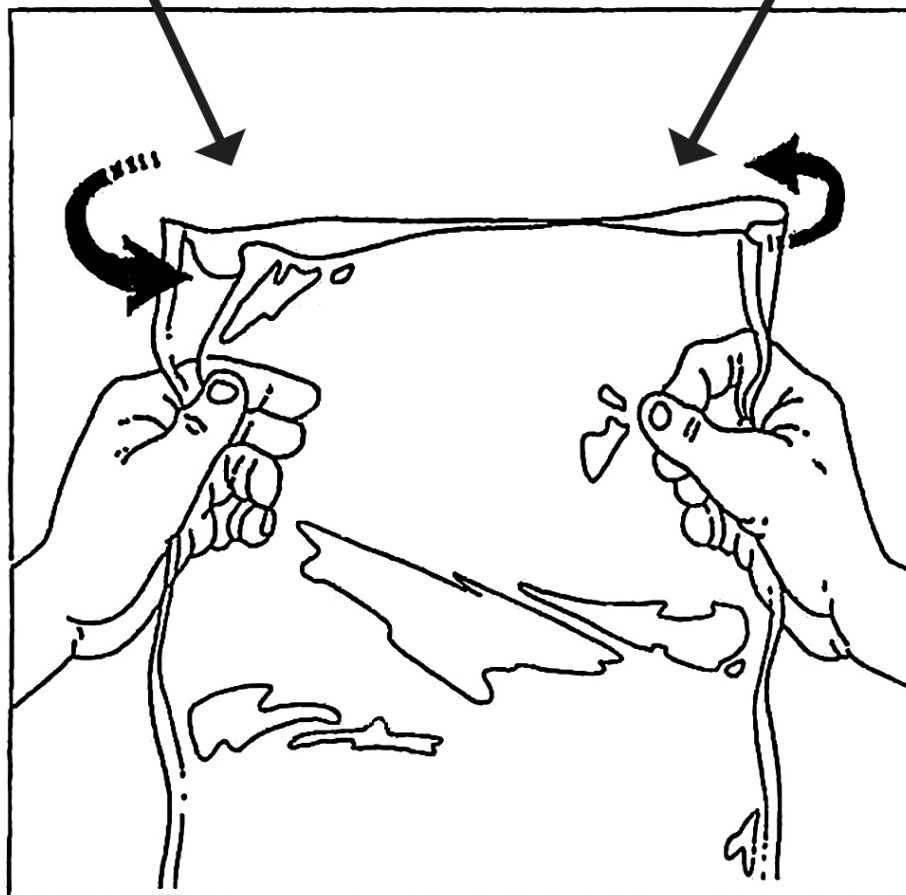

(I)