



COUNTER TOP REFRIGERATORS

Modelnr.: *682.001 - *682.002 - *682.003
*682.004 - *682.010



USER'S MANUAL

Attention: before removing the packaging of your refrigerator carefully read the operation instructions in this user's guide (possible damages due to a failure in following these instructions are not considered in the warranty).

PACKAGING.

Despite the care the manufacturer always puts when packing their refrigerators to ensure that no damage occurs during the transport, it may happen that the carrier delivers a parcel visibly damaged. In this case the customer is required to notify details of any damage on the transportation document of the carrier in order to put in a complaint if the merchandise is damaged. In case of doubt do not use the refrigerator and refer to qualified personnel for any tests.

Once pulled out the refrigerator please keep the packaging in a dry place in order to reuse it in case the machine must be returned to the manufacturer for any eventually. We will not respond to damages of refrigerators returned into packaging different from the original one.

INSTALLATION.

- After removing the refrigerator from its packaging, leave it in a horizontal position for at least 30 minutes.
- The refrigerator must be installed on a flat surface but can be raised of about 5 cm in its back side to allow a better access to the basins.
- In the meantime check the basins correspond to those chosen ordered with the refrigerator.
- Check the switch is on the OFF position (0) and the electrical data indicated on the plate are compatible with the electric power source.
- Make sure the installation area on which the refrigerator will be placed is protected and quite far from the heating rays originating from ovens.
- Make sure the inlet - outlet air grills are not obstructed in order to allow a correct and natural air recycling: We advise to leave a space of 10 cm at least.
- An anomalous installation not in accordance to the above-mentioned instructions affects both the correct operation of the refrigerator and its life-time and annul your warranty.
- Connect the plug to the electrical system ensuring that the latter is in compliance with the Laws in force (differential circuit-breaker, earthing connection, etc.). Please remember that a faulty power source could irreparably damage some components of your refrigerator and as well as invalidating the warranty.
- Generally we advise against the utilization of adapters, multiple plates and/or extensions. Otherwise use only fittings in conformity with the safety rules in force. Do not modify the power cord supplied.
- Do not connect the refrigerator to the electrical system with wet hands and/or bare feet.
- Do not unplug by pulling on the cord.
- Do not allow children and / or unable to use the refrigerator without supervision
- However avoid your refrigerator suffers strokes or sudden movements that could compromise its life-time and its operation. NOTE: A properly cleaning of the basins is strictly necessary before putting food into them.

START UP.

- To start-up your refrigerator press the GREEN BUTTON by putting it on "ON" (1) and control the compressor starts up within 60 seconds.
- If you haven't already inserted the basins into the refrigerator please cover the basins holder with a cardboard to prevent cold air dispersion.
- After a time variable among 90 and 120 minutes the refrigerator reaches the factory pre-set temperature of 4°C.
- To modify this temperature read the instructions of the control unit (paragraph SET POINT SETTINGS): normally you have to press the SET button, by means of the UP and DOWN buttons temperature will change and pressing SET again new data will saved.
- Food must be place into basins only when the machine reaches the proper temperature because this type of refrigerator maintains the temperature because it is not a blast chiller.
- We advise the basins never be filled more than 80% of their capacity and keep them closed with their lid as much as possible. Thus the food will be better preserved.

USE AND MAINTENANCE.

It is very important to dedicate a short time for the maintenance of your refrigerator in order to maintain it in perfect efficiency and for a long life-time,

- **Every week clean the air filter** placed inlet the fan of the refrigerator to avoid the infiltration of flour, dust, grease, oil, etc.
- The air filter removal is easy and does not need particular tools: just a little pressure on the two sides of the safety grid occurs to lift it, then remove the filter
- For a proper cleaning it is necessary to immerse the filter in warm water added with detergent, rinse it and wipe with a cloth, If the filter is only covered with dust an air blow is sufficient to clean it.
- Before replace it in its site control it is not damage or unusable: in this case you have to replace it with a new one of the same type and thickness (the manufacturer always provides some spare parts).
- Regularly clean the refrigerator (once a week at least) using a sponge and warm water: it is strictly forbidden to use pointed or cutting metal objects, solvents or aggressive chemicals.
- Sure before cleaning your refrigerator disconnect the plug from the wiring and wait a few minutes in order to permit the melting of the frost on the inner walls.

IT IS STRICTLY FORNIDDEN AND EXTREMELY DANGEROUS

to throw water or sprinklings on the electrical circuits (fan, suction grids, switch, thermostat, etc.)

OPERATION PROBLEMS AND SOLUTIONS.

(1) THE REFRIGERATOR DOES NOT TURN ON

SOLUTIONS:

- First check the socket is connected and the plug supplies current regularly
- If the refrigerator does not turn on again, (green light off) check the power cable is not damage and if so, only a technician can replace it.

(2) THE REFRIGERATOR DOES NOT COOL OR IT DOES NOT REACH THE PRE-SET TEMPERATURE

SOLUTIONS:

- Check the thermostat is on and set on the right temperature so that lower than that of the environment, on the display of the control unit check the operating LED is on and the compressor is on work (you should hear the noise of the motor)
After five working minutes control the condenser (aluminium exchanger placed laterally behind the perforated grid) exhales an hot airflow from its upper side. If not, it could be a problem on the compressor or a lack of gas from the refrigerant circuit or the fan is blocked so you have to contact a technician.
- Control the condenser is dirty or obstructed: in that case clean it using a jet of compressed air.
- Control that the room temperature is not over 40°C.

(3) THE CONTROL UNIT GOES INTO ALARM

- If the control unit beeps it means the maximum required time to allow the refrigerator reaches the set temperature is over.

SOLUTIONS:

- Carry out the same controls mentioned in point (2).
- If the display shows blink characters please contact the after-sale service.

(4) THE CONTROL UNIT SHOWS A FAILURE (ERR)

SOLUTIONS:

- It means the probe of the thermostat doesn't work properly and you must replaced it.
Contact the after-sale service.

WARRANTY

The warranty on our refrigerators is valid for 12 months from the date of delivery of the machine; the date is on the transport document signed by the purchaser or by an authorized delegated. During the period of the warranty and if there are construction faults directly attributable to the manufacturer and not due to liability of the purchaser, the manufacturer will supply, on his discretion:

- (a) the replacement of the non-repairable parts.
- (b) the repairing of all repairable parts.

The purchaser takes note of this document and commits to approve the decisions of the manufacturer renouncing to any other claim, also for direct and indirect damages and he will not claim costs for machine stop, loss of work and other kind of damages.

In case of damages that required the returning of your refrigerator to the manufacturer for repairings, it must be delivery into its original packaging by carriage paid; it will be repair in a reasonable time and then returned to the purchaser; all transportation charges will be paid by the manufacturer. Besides, in case of returning to the manufacturer of refrigerators to be repair, any damage happened during the transport due to an inappropriate packaging will be charged to the purchaser.

The warranty is invalid for any cause attributable to commissive or omissive behaviours attributable to the purchaser. Particularly the warranty is invalid in case of:

- (a) Shortage of maintenance or cleaning by the purchaser
- (b) Failure of use and maintenance instructions
- (c) Unauthorised use and negligence
- (d) Non original spare parts utilization
- (e) Tampering
- (f) Normal wear and tear

The manufacturer promises to replace all defective components of the refrigerator, including those not directly produced by him. The replacement is limited to the component supplying: all delivery charges will be paid by the customer.

The warranty is invalid in case of damages due to a non-timely or omitted request of intervention. Any intervention, repairing or modification carried out by the customer or unauthorized person without written authorization by the manufacturer will be consider as a tampering under penalty of cancellation of the warranty.

DECLARATLON OF CONFORMITY ISSUED BY THE MANUFACTURER

Refrigerators for basins EURO-GASTRONORM are designed and manufactured in accordance with the International Standards EN 60335-2-24, EN 50081-1, EN 50082-1 and comply with the following directives:

- Directive 2006/42/EC of the European Parliament and of the Council of 17 May 2006, on machinery and amending Directive 95/16/EC
- Directive 2004/108/EC of the European Parliament and of the Council of 15 December 04, on the approximation of the laws of the Member States relating to electromagnetic compatibility
- Directive 2006/95/EC of the European Parliament and of the Council of 12 December 2006, on the harmonisation of the laws of the Member States relating to electrical equipment designed for use within certain voltage limits

DISPOSAL OF ELECTRICAL AND ELECTRONIC WASTE

At the end of their life-time the refrigerator must be disposed following the laws in force relative to the differentiated waste disposal and it must not be treated as a urban waste.

The refrigerator must be disposed into dedicated collection centres or must returned to the reseller in case you need to replace your refrigerator with a new one. The manufacturer will be responsible for all costs of the disposal as required by the law.

The refrigerator is composed by some non-biodegradable parts and by polluting substances if not suitably disposed. Besides part of these materials can be recycled avoiding the environmental pollution.

Your and our duty is to contribute to the health of the environment.

The symbol of the crossed casing indicates the product complies with the Directives (2002/96/EC, 2003/108/EC, 2002/95/EC) introduced to protect the environment and it must be disposed in an appropriate way at the end of its time-life.

Get more information from local authorities about the areas devoted to waste disposal.

Those who do not dispose the product following how mentioned in this paragraph shall respond in accordance with the regulations in force.

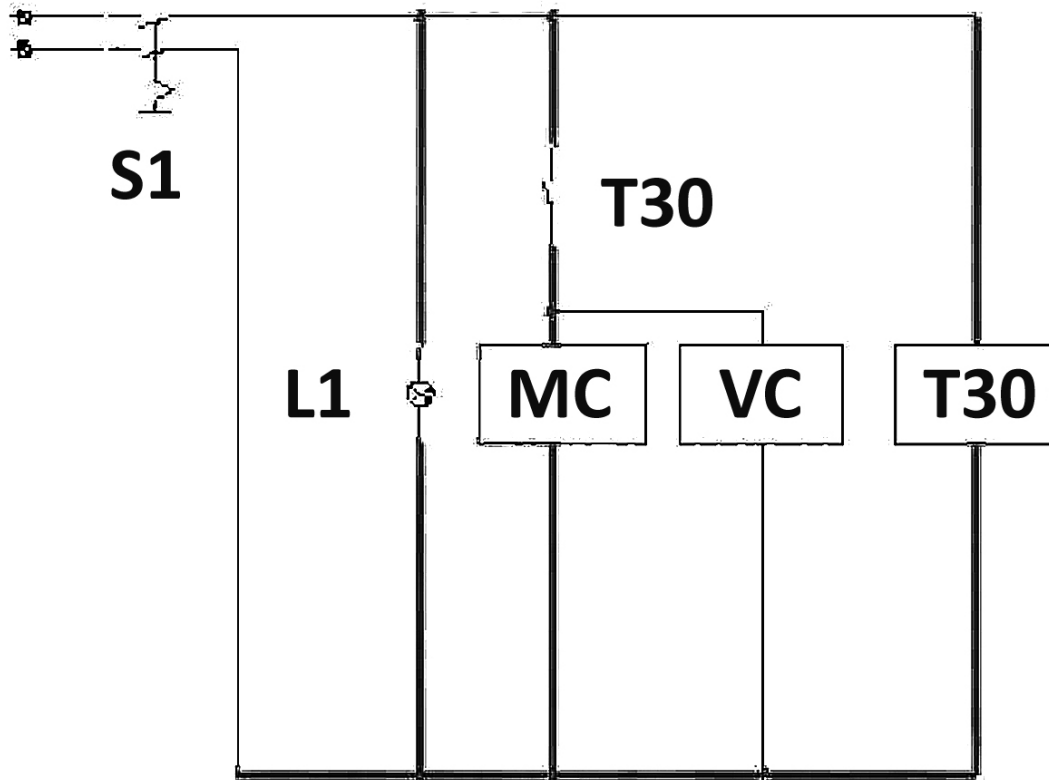

WIRING DIAGRAM

S1 = SWITCH
 T30 = CONTROL
 MC = COMPRESSOR
 VC = FAN
 LI = LIGHT ON/OFF

For cables connection please refer to the user's guide of the control unit.

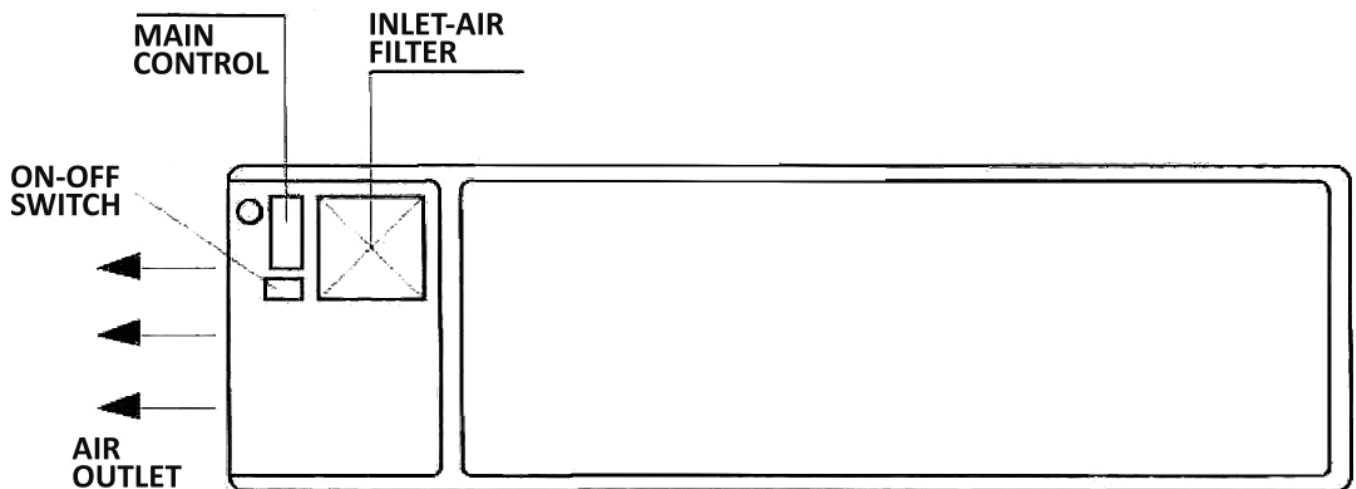

REFRIGERATOR CIRCUIT SCHEME

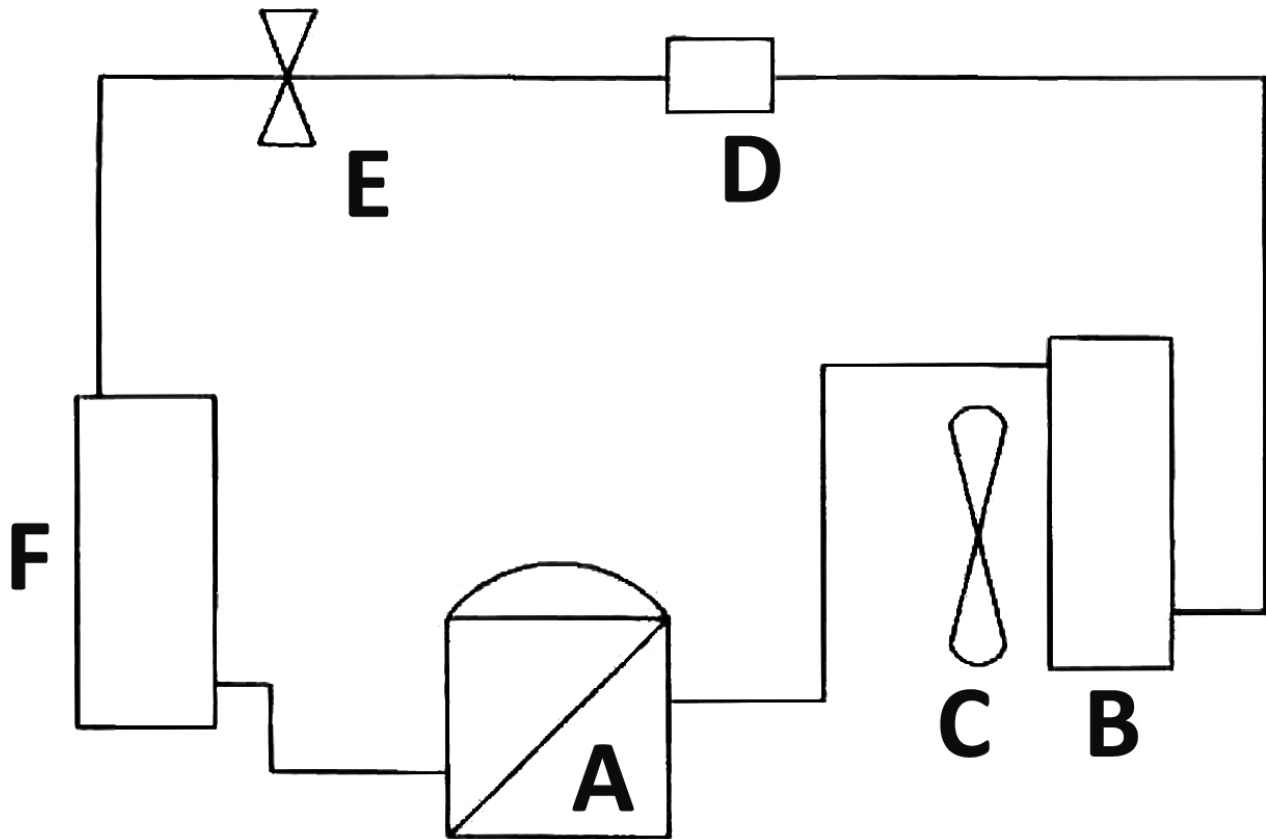

A = COMPRESSOR
B = CONDENSER
C = FAN

D = FILTER
E = CAPILLARY
F = EVAPORATOR